

TABLE I: STREET NAME SIGN DIMENSIONS

| | GROUP "A" (POST TOP MOUNTED) | GROUP "B" ARTERIAL (POST TOP MOUNTED) | GROUP "C" SUPPORT POLL/MAST ARM |
|--|---------------------------------|--|------------------------------------|
| B (BLADE HEIGHT) | 8" | 12" | 18" |
| M (MARGIN) | 1/2" | 3/4" | 1" |
| D (DISTANCE FROM EDGE) | 3" | 3" | 4" |
| MAIN TEXT HEIGHT | 4" | 6" | 10" |
| SUFFIX/PREFEX TEXT HEIGHT | 2 1/2" | 3 3/4" | 6 2/3" |
| "CITY OF MARYSVILLE/YEAR" TEXT HEIGHT | 1/4" | 1/2" | 3/4" |

NOT TO SCALE

Date: 1/1/20

Standard Construction Drawing



TYPICAL STREET NAME SIGN

Drawing No.

STR-17
Sheet 1 of 6



NOT TO SCALE

Date: 1/1/20

Standard Construction Drawing



GROUP B STREET MAP

Drawing No.

STR-17
Sheet 2 of 6

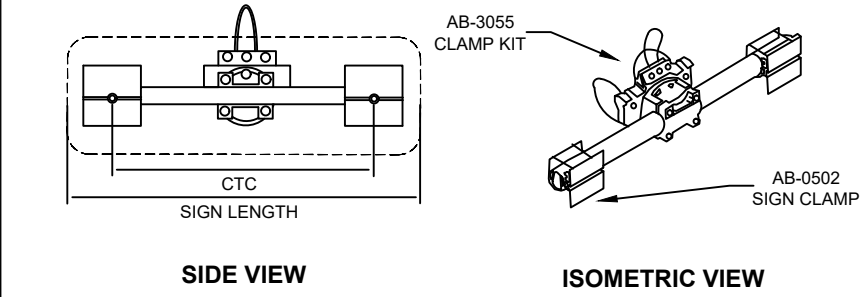
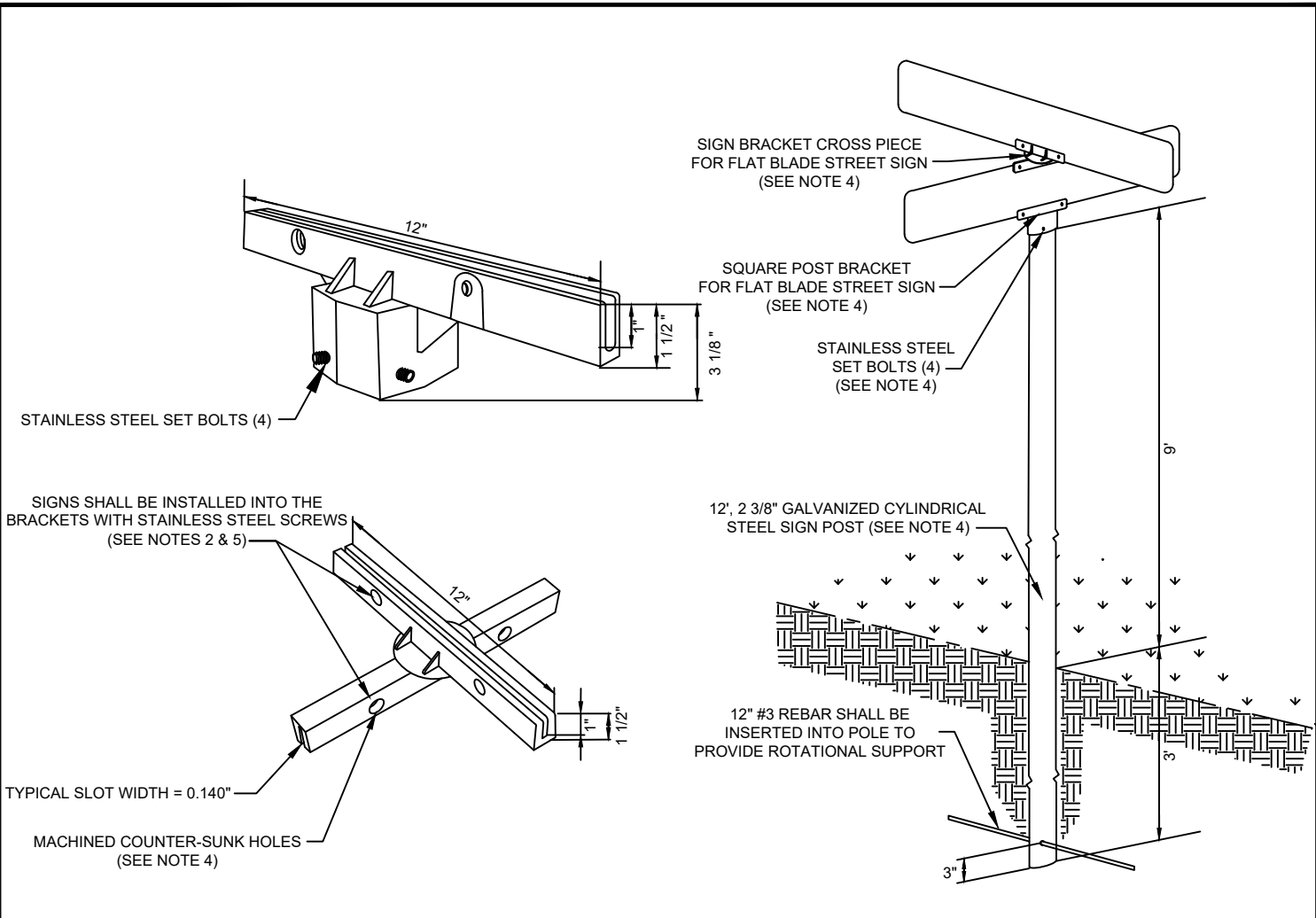

NOTE:
 - FOR OVERHEAD MAST ARM MOUNTED STREET NAME SIGNS THE ASTRO SIGN-BRAC GALAXY CABLE MOUNT MODEL AG-0144 OR APPROVED EQUAL SHALL BE USED
 - MOUNTING CABLES AND CLAMP KIT COLOR SHALL MATCH THE MAST ARM POLE

| STREET NAME MAST ARM MOUNT REQUIREMENTS (INCHES) | | | | | | | | | | | | | | | | | |
|--|---------------|----|----|----|---------------|----|----|----|----|----|----|----|---------------|----|-----|-----|-----|
| | 2 SIGN CLAMPS | | | | 4 SIGN CLAMPS | | | | | | | | 6 SIGN CLAMPS | | | | |
| SIGN LENGTH | 18 | 24 | 30 | 36 | 42 | 48 | 54 | 60 | 66 | 72 | 78 | 84 | 90 | 96 | 102 | 108 | 114 |
| MAX. CTC | 12 | 18 | 24 | 30 | 36 | 42 | 48 | 54 | 60 | 66 | 72 | 78 | 84 | 90 | 96 | 102 | 108 |

NOT TO SCALE

Date: 1/1/20 Standard Construction Drawing



TYPICAL STREET NAME SIGN

Drawing No.
STR-17
Sheet 3 of 6

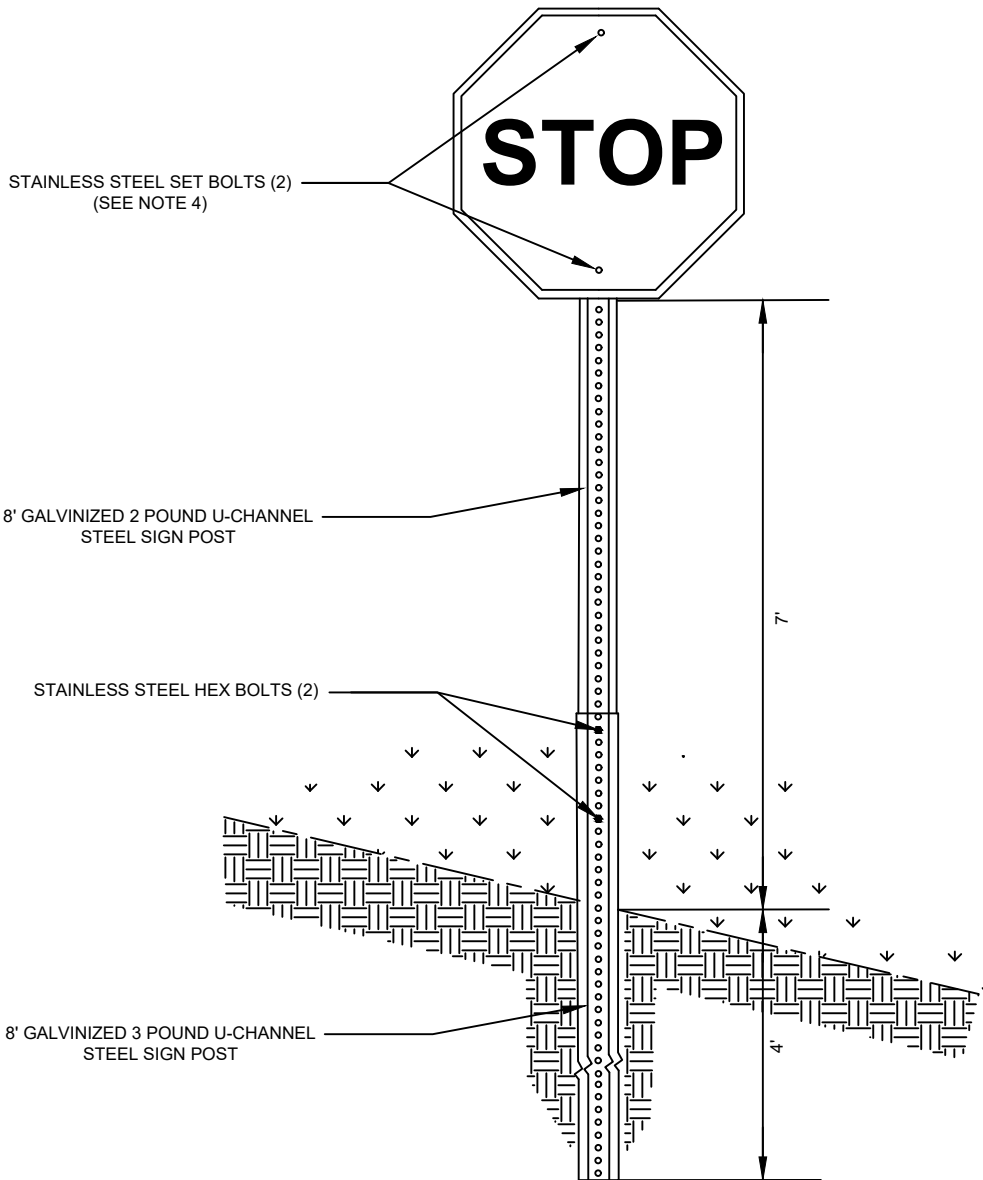

NOT TO SCALE

Date: 1/1/20

Standard Construction Drawing



TYPICAL REGULATORY
& WARNING SIGNS

Drawing No.

STR-17
Sheet 4 of 6

NOTE:
 AT ALL UN-SIGNALIZED ARTERIAL
 INTERSECTIONS STREET SIGNS
 SHALL BE SEPARATED ON
 INDIVIDUAL POLES

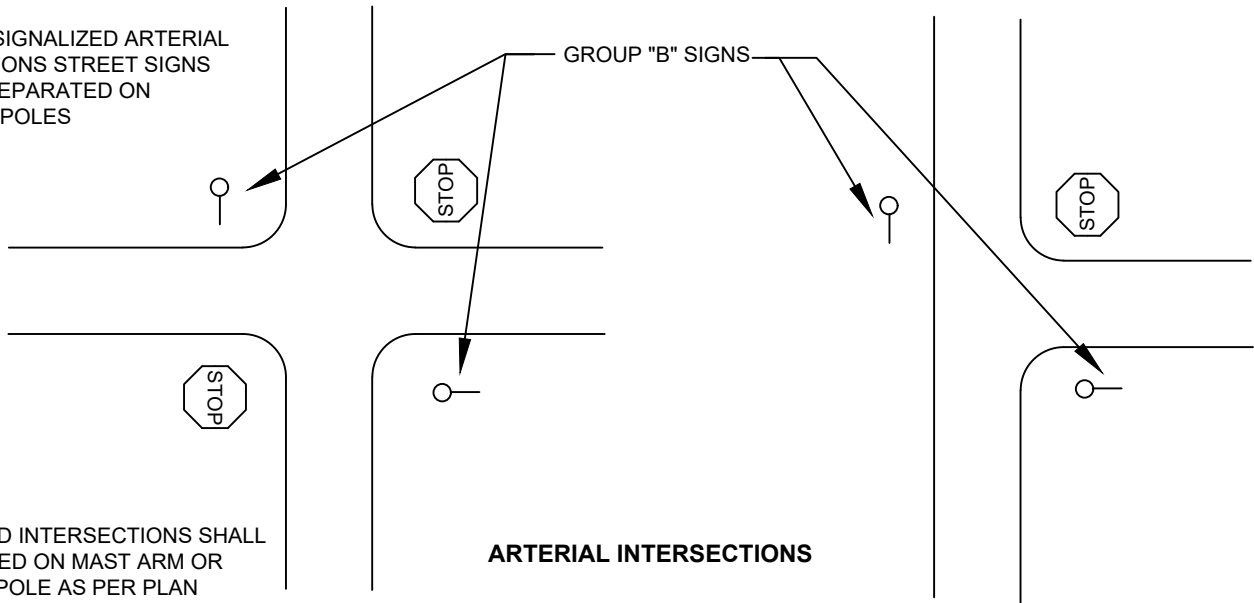

NOTE:
 SIGNALIZED INTERSECTIONS SHALL
 BE MOUNTED ON MAST ARM OR
 SUPPORT POLE AS PER PLAN

ARTERIAL INTERSECTIONS

NOTE:
 AT ALL LOCAL INTERSECTIONS
 STREET SIGNS SHALL BE
 INSTALLED WITH TWO SIGNS PER
 POST. IF THE COMBINED SQUARE
 FOOTAGE OF THE TWO SIGNS
 EXCEEDS 10 SQUARE FEET USE
 THE INDIVIDUAL POSTS FOR EACH
 SIGN ABOVE.

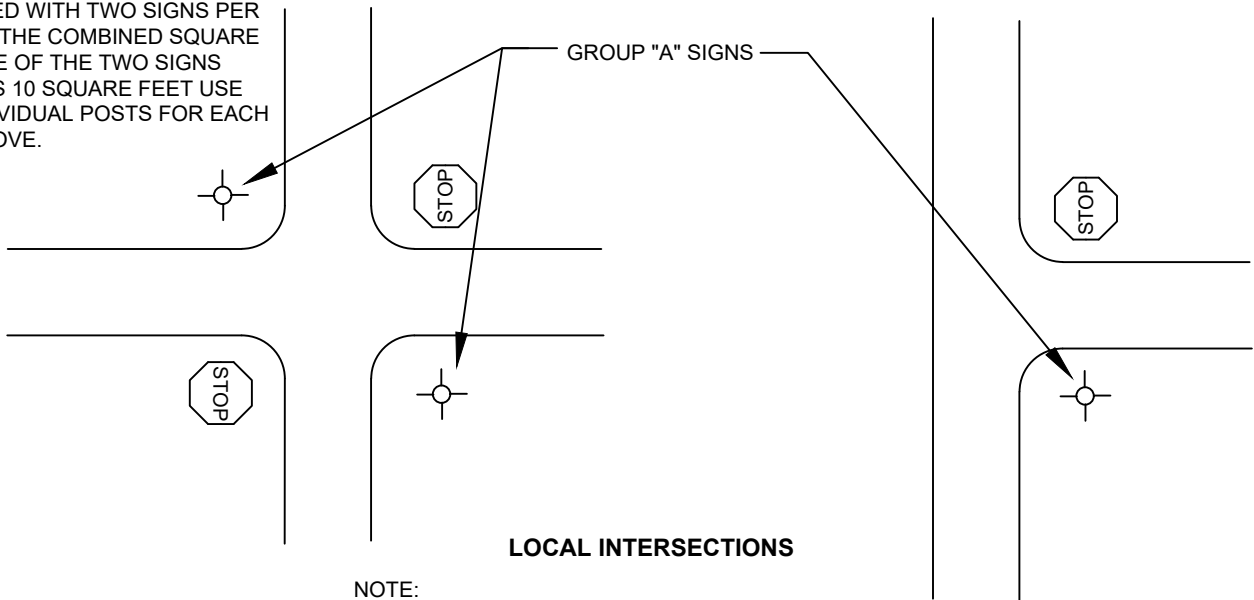

LOCAL INTERSECTIONS

NOTE:
 IF EITHER OF THE ABOVE CONFIGURATIONS ARE
 IMPOSSIBLE THEN THE CONTRACTOR SHALL
 INSTALL THE SIGNS IN SUCH A MANOR AS TO
 MINIMIZE OBSTRUCTION OF OTHER TRAFFIC
 CONTROL SIGNS.
 CONFIGURATION IS TO BE APPROVED BY THE
 CITY ENGINEER.

NOT TO SCALE

Date: 1/1/20

Standard Construction Drawing



STREET NAME SIGN PLACEMENT

Drawing No.

STR-17
 Sheet 5 of 6

DETAIL NOTES:

1. ALL REGULATORY AND TRAFFIC CONTROL SIGNS SHALL COMPLY WITH THE CURRENT OHIO MANUAL OF UNIFORM TRAFFIC CONTROL DEVICES FOR STREETS AND HIGHWAYS, STATE REQUIREMENTS AND LOCAL REQUIREMENTS. THE REQUIREMENTS OF THIS SPECIFICATION INCLUDING PAINTING, APPLY TO ALL PERMANENT SIGNS WHETHER THEY ARE GROUND MOUNTED ON POSTS OR POLE SUPPORTS, OR OVERHEAD MOUNTED ON MAST ARMS. THIS SPECIFICATION SHALL NOT APPLY TO TEMPORARY SIGNS.
2. ALL MOUNTING AND ASSEMBLY HARDWARE: NUTS, BOLTS, DRIVE RIVETS AND POP RIVETS SHALL BE STAINLESS STEEL.
3. ALL STREET NAME SIGNS WILL BE MOUNTED ON 2 3/8" CYLINDRICAL, 12' LONG, 16 GAUGE (OR THICKER) GALVANIZED TUBULAR STEEL SIGN POSTS. STREET NAME SIGN POSTS SHALL BE INSTALLED 3' BELOW GRADE ALL OTHER SIGNS SHALL BE INSTALLED 4' BELOW GRADE.
4. THE BRACKETS SHALL BE DIE-CAST OF HIGH STRENGTH ALUMINUM ALLOY NO. 380 UNDER 400 TONS PRESSURE, WITH A MINIMUM STRENGTH OF 45,000 P.S.I., DEGREASED, POLISHED AND TUMBLED TO A LOW-SHEEN FINISH. THE SIGN SLOT IN THE CYLINDRICAL POST BRACKET AND THE SIGN BRACKET CROSS PIECE SHALL HAVE DIMENSIONS AS SHOWN. EACH LEG OF THE MOUNT SHALL BE CAST WITH TWO (2) HOLES COUNTER-SUNK ON OPPOSITE SIDES AND DRILLED AND TAPPED TO ACCEPT TWO HEX-HEAD STAINLESS STEEL BOLTS ON THE OPPOSITE SIDE OF THE COUNTERSUNK HOLE. THE SIDE OF EACH SLOT OPPOSITE THE SET SCREWS SHALL BE CAST OR MACHINED ACCURATELY HORIZONTAL. THE SKIRT OF THE SQUARE POST BRACKET SHALL BE DRILLED AND TAPPED FOR TWO (4) BOLTS.
5. THE POST SHALL BE SET VERTICALLY IN ALL DIRECTIONS AND THE SIGNS PARALLEL TO THEIR RESPECTIVE ROADWAYS.
6. ALL STREET SIGNS SHALL BE INSTALLED IN LOCATIONS AS SHOWN ON THE STREET PLANS, IN ACCORDANCE WITH THESE SPECIFICATIONS AND PRIOR TO ACCEPTANCE OF THE STREETS BY THE CITY.
7. THE DEVELOPER MAY MAKE ARRANGEMENTS WITH THE ENGINEER TO FURNISH AND INSTALL THE SIGNS. ALL COSTS SHALL BE PAID BY THE DEVELOPER.
8. SIGN POSTS ARE NOT TO BE INSTALLED INTO CONCRETE CURB OR SIDEWALK.
9. "U-CHANNEL" POSTS ARE NOT ACCEPTABLE FOR STREET NAME SIGNS.
10. EACH SIDE OF THE ALUMINUM STREET NAME SIGN BLANKS SHALL BE BORDERED WITH WHITE HI-INTENSITY WHITE 3M SCOTCHLITE® OR EQUAL, PRESSURE SENSITIVE PAPER ALONG THE OUTSIDE EDGE.
11. ALL STREET SIGN LETTERING IS TO BE HIGHWAY "C" FONT USING HI-INTENSITY WHITE 3M SCOTCHLITE®, OR EQUAL, PRESSURE SENSITIVE PAPER. SEE THE TABLE 1 (SHEET 1) FOR LETTERING SIZES.
12. THE FIRST LETTER OF EACH WORD OF THE PREFIX, STREET NAME STREET TYPE, AND/OR SUFFIX IS TO BE CAPITALIZED FOLLOWED BY LOWER CASE LETTERS. STREET TYPE ABBREVIATIONS SHALL CONSIST OF THE FOLLOWING; BLVD, RD, ST, PKWY, LN.
13. NO PERIODS OR OTHER PUNCTUATION MARKS ARE TO BE USED IN THE PREFIX, SUFFIX, OR STREET NAME.
14. SIGNS SHALL NOT BE ALLOWED TO OVERLAP OTHER SIGNS.
15. STREET SIGN STYLES THAT DIFFER FROM THIS STANDARD MUST BE APPROVED IN WRITING BY THE CITY OF MARYSVILLE ENGINEER AND/OR THE PLANNING COMMISSION PRIOR TO INSTALLATION.
16. "CITY OF MARYSVILLE" & MANUFACTURED YEAR SHALL BE PRINTED IN GREEN LETTERS IN THE BOTTOM WHITE MARGIN PER THESE SPECIFICATIONS.
17. THE SHAPE OF ANY TRAFFIC SIGN IS REQUIRED TO BE VISIBLE AT ALL TIMES WHEN APPROACHING FROM THE OPPOSITE DIRECTION.
18. IN RESIDENTIAL AREAS SIGNS INDICATING "SPEED LIMIT" AND "NO PARKING" ARE TO BE INSTALLED AS CLOSE AS POSSIBLE TO THE MEDIAN BETWEEN LOTS.

| | | |
|---|-------------------------------|--|
| Date: 1/1/20 | Standard Construction Drawing | |
|  | TRAFFIC SIGN NOTES | Drawing No. STR-17 Sheet 6 of 6 |