

PROFILE

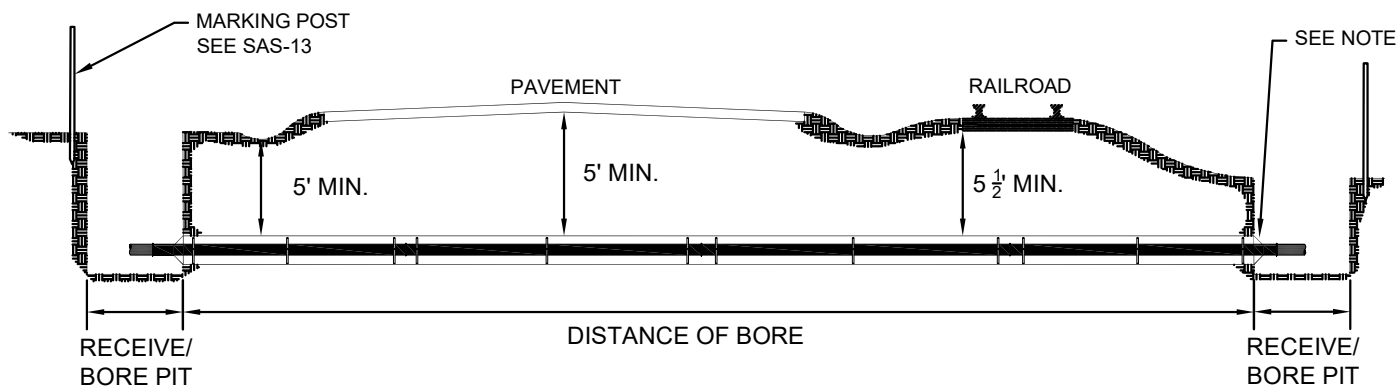

SIDE VIEW

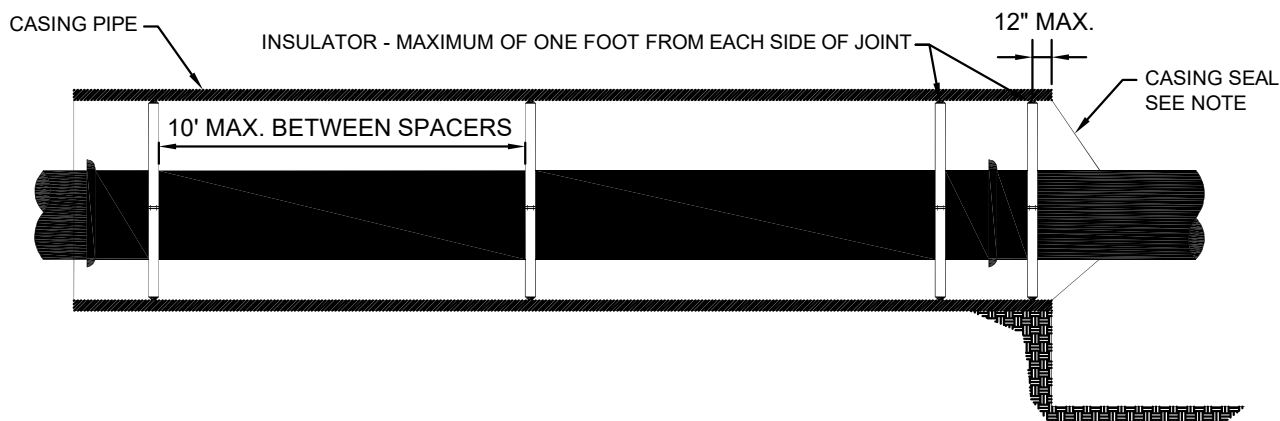

END VIEW

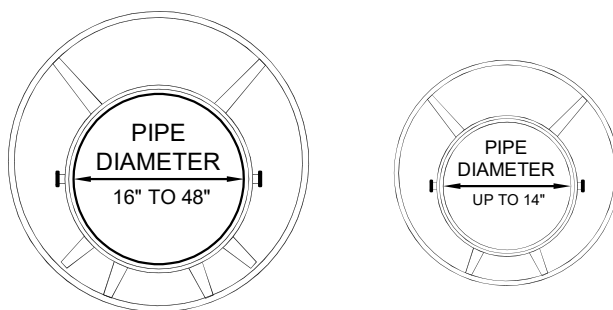

NOTE:
SEE TABLE 1 FOR CASING/CARRIER
PIPE SPECIFICATIONS

NOT TO SCALE

DATE: MARCH 2023

STANDARD CONSTRUCTION DRAWING



JACK & BORE DETAIL

DRAWING NO.
SAS-17
SHEET 1 OF 2

Note:

1. CARRIER SPACERS SHALL BE STAINLESS STEEL WITH 2 " WIDE PLASTIC RUNNERS. WOOD SPACERS ARE NOT PERMITTED.
2. CARRIER PIPE SHALL HAVE LOCKING JOINTS PER CITY OF MARYSVILLE STANDARD DRAWING WTR-03
3. ALTERNATE METHODS OF CASING SPACERS MAY BE UTILIZED UPON APPROVAL OF CITY ENGINEER.
4. SEAL ANNULUS BETWEEN CARRIER PIPE AND CASING AT BOTH ENDS USING CASING SEAL AS MANUFACTURED BY PIPELINE SEAL AND INSULATOR, MODEL S OR APPROVED EQUAL. ALTERNATE METHOD IS TO SEAL ANNULUS WITH 8 " THICK ASTM C32 GRADE MS BRICK BULKHEAD.
5. ALL CASING PIPE SHALL BE WELDED STEEL PIPE CONFORMING TO ASTM A139 CLASS B. COATING FOR STEEL CASING IS NOT REQUIRED.
6. WHEN CROSSING PAVEMENT OR RAILROAD THE CASING PIPE SHALL EXTEND AT LEAST 10' ON EITHER SIDE OR AS REQUIRED BY THE APPROPRIATE PERMITTING AGENCY.
7. TRACING WIRE SHALL BE INSTALLED THROUGH ALL CASED BORINGS AND CONNECTED TO MARKING POSTS.
8. CONNECT TRACER WIRE TO CASING PIPE WITH DISCONNECT ON EITHER SIDE (TEST STATION)
9. FILL ENTIRE LENGTH OF CARRIER PIPE WITH FLOWABLE FILL CDF.
10. A VENT MUST BE INSTALLED ON BOTH ENDS OF THE CASING PIPE DURING CONSTRUCTION TO FACILITATE THE FILL OPERATION.

TABLE 1

NOMINAL CARRIER PIPE DIAMETER	6 "	8 "	10 "	12 "	15 "	18 "	21 "	24 "
MINIMUM CASING PIPE DIAMETER	14 "	16 "	20 "	20 "	24 "	30 "	30 "	36 "
MINIMUM WALL THICKNESS	.281 "	.281 "	.343 "	.343 "	.406 "	.469 "	.469 "	.531 "

DATE: MARCH 2023

STANDARD CONSTRUCTION DRAWING



JACK & BORE NOTES

DRAWING NO.

SAS-17

SHEET 2 OF 2